



To cite this article: Iman Setiadi, Ida Bagus Made Agung Dwijatenaya, Agustinus Djiu and Yonathan Palinggi (2024). Analysis Of The Effect Of Implementation Of Corporate Social Responsibility (Csr) Policy On Community Welfare. International Journal of Education, Business and Economics Research (IJEBER) 4 (2): 400-410

## ANALYSIS OF THE EFFECT OF IMPLEMENTATION OF CORPORATE SOCIAL RESPONSIBILITY (CSR) POLICY ON COMMUNITY WELFARE

Iman Setiadi<sup>1</sup>, Ida Bagus Made Agung Dwijatenaya<sup>2</sup>  
Agustinus Djiu<sup>3</sup> and Yonathan Palinggi<sup>4</sup>

<sup>1234</sup>Kutai Kartanegara Tenggara University, Indonesia

<https://doi.org/10.59822/IJEBER.2024.4219>

### ABSTRACT

The research aims to analyze the influence of CSR Policy Implementation (economic, educational, health, socio-cultural and environmental dimensions), both partially and simultaneously on community welfare. This research uses a quantitative research design. The research was carried out in Bentian Sub district, Kutai Barat Regency, East Kalimantan, Indonesia from August to November 2023. This research used multiple regression analysis. The results of the research were that the influence of CSR on economic, health, social, cultural and environmental aspects has a positive and significant effect on community welfare. Meanwhile, the influence of CSR on the education aspect not significant effect on community welfare. CSR together (simultaneously) has a significant effect ( $0.00 < 0.05$ ) on community welfare. Recommendations that could be conveyed were: companies in implementing CSR so that it was equitable for the community, optimizing CSR programs that are able to improve the community's economy by paying attention to the potential of local communities, companies to pay attention to environmental comfort and maintaining sustainable agricultural land, and companies not to carry out land conversion.

**KEYWORDS:** Economy, Education, Health, Social Culture, Environment, Community Welfare.

© The Authors 2024  
Published Online: Apr 2024

Published by International Journal of Education, Business and Economics Research (IJEBER) (<https://ijeber.com/>) This article is published under the Creative Commons Attribution (CC BY 4.0) license. Anyone may reproduce, distribute, translate and create derivative works of this article (for both commercial and non-commercial purposes), subject to full attribution to the original publication and authors. The full terms of this license may be seen at: <http://creativecommons.org/licences/by/4.0/legalcode>

### 1. INTRODUCTION

Improving people's welfare has become the nation's commitment, as stated in the 17 SDGs, namely goal one, ending poverty in all forms everywhere, and goal three, which states ensuring healthy lives and supporting prosperity for all at all ages. To achieve this goal, the regional government makes efforts based on the authority it has. Community prosperity will be achieved if all

stakeholders play their roles well. Likewise, companies, through the implementation of CSR programs.

In light of the current effects of globalization, information technology advancements, and market openness, businesses need to take corporate social responsibility (CSR) very seriously. Kutai Barat Regency has to implement CSR, and this requires attention from the administration, the community at large, and the participating companies. The improvement of community welfare, including programs related to health, education, economics, socioculture, religion, community relations, infrastructure, and the environment, is the constant goal of the implementation of CSR initiatives. Companies should implement CSR practices in order to strengthen their ties to the community. Companies must establish good and harmonious relationships with the community and with stakeholders. The reality on the ground is that it is not uncommon for there to be poor relations between companies and the community (Rudito & Famiola, 2019).

## **2. LITERATURE REVIEW**

Policy is a principle or way of acting chosen to guide decision-making. The policy consists of agenda setting, policy formulation, policy adoption, policy implementation, and policy assessment (Dunn, 2003). In line with technological advances, all aspects of company activities will always be in the spotlight of the wider community. Whether a company has carried out its CSR (corporate social responsibility) obligations in accordance with statutory regulations or not. CSR is an organization's responsibility for the impact of its decisions and activities on society and the environment which is manifested in the form of transparent and ethical behavior that is in line with sustainable development and community welfare (Putra, 2015). CSR is widely considered as a responsibility that is worth carrying out to ensure the creation of sustainable benefits for the company and society. CSR is an important foundation for a business to build stakeholder trust and confidence (Urip, 2014).

The implementation of CSR policies by companies is carried out through various programs which include the dimensions; economy, education, health, social culture, religion, environment and infrastructure. The Education dimension CSR variable has a positive and significant effect on community welfare (Sa'adah & Azis, 2019). CSR in economic, social and environmental aspects has an influence on community welfare (Ningtyas et al., 2022). The implementation of CSR programs has basically been implemented in various main activities such as: education, health, poverty, social, religion, infrastructure and the environment which have an impact on community welfare.

Welfare is the life goal of every human being in the world, and countries always strive to ensure that their society is prosperous. Likewise, the company will try to improve the welfare of its employees. (Sastrohadiwiryo, 2005) states that to improve the welfare of employees and their

families, companies provide welfare facilities by taking into account the needs of workers and the company's capabilities. Welfare programs, especially for companies, as stated by (Dessler, 1992), can provide supplementary pay allowances, insurance benefits, old age benefits and services. The opposite of prosperity is poverty, if you are not prosperous you are poor. These two words are seen to have almost the same meaning. Poverty is a problem in development which is characterized by unemployment and backwardness, which then increases into inequality (Kartasasmita, 1996). Anti-poverty policies that lead to improving people's welfare are starting to be discussed. The rise of the welfare state is characterized by governments resisting market pressures to protect individuals from certain contingencies and to guarantee people a minimum standard of living (Samuelson & Nordhaus, 2003). (Pakpahan, 2021) said that there are various types of welfare measurements or indicators that have been developed by researchers. According to (Stiglitz et al., 2011) the dimensions of measuring welfare consist of: material living standards (income, consumption and wealth), health, education, individual activities including work, political voice and governance, social relations and kinship, environment. life (present and future conditions), as well as insecurity, both economic and physical.

Previous research related to the implementation of CSR on welfare referred to is research (Syarifuddin, 2020) examining with the title the impact of CSR on the welfare of the PT livestock community. PLN Tanjung Jati B. Other research related to this research is (Astuti, 2018), (Alfian & Rahayu, 2019), (Djamiluddin et al., 2021), (Ningtyas et al., 2022), and (Razak et al. , 2022).

Referring to the theoretical basis and previous research, a conceptual framework was then prepared. The main theory used in this research uses welfare theory (Stiglitz et al., 2011) and the supporting theory is CSR theory (Putra, 2015). The previous research referred to is (Ningtyas et al., 2022). Economic aspects, educational aspects, health, socio-cultural and environmental aspects are independent research variables, while the dependent variable is welfare. Next, a conceptual framework was prepared as shown in Figure 1.

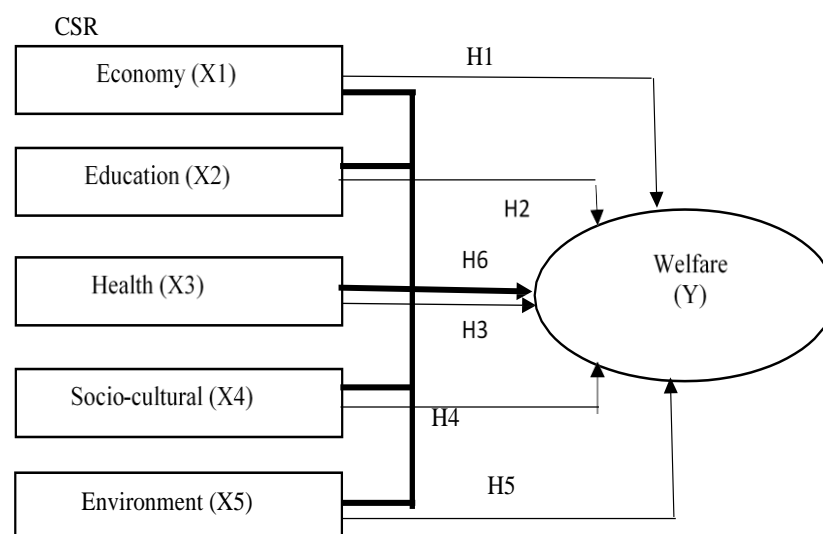

**Figure 1**  
**Research Conceptual Framework, 2024**

Based on the conceptual framework in Figure 1, the next hypothesis proposed is:

- 1) It is suspected that the influence of the economic dimension of CSR Policy Implementation will partially have a positive and significant influence on community welfare.
- 2) It is suspected that the influence of CSR Policy Implementation in the educational dimension partially has a positive and significant effect on community welfare.
- 3) It is suspected that the influence of CSR Policy Implementation on the health dimension partially has a positive and significant effect on community welfare.
- 4) It is suspected that the influence of CSR Policy Implementation in the socio-cultural dimension partially has a positive and significant effect on community welfare.
- 5) It is suspected that the influence of CSR Policy Implementation in the environmental dimension partially has a positive and significant effect on community welfare.
- 6) It is suspected that the influence of CSR Policy Implementation simultaneously has a positive and significant effect on community welfare.

The purpose of this study was to examine the partial and simultaneous effects on community welfare of the implementation of CSR policies (economic, educational, health, socio-cultural, and environmental).

### **3. RESEARCH METHOD**

This research uses a quantitative research design with an inferential statistical approach (Sugiyono, 2012). Inferential statistics is a statistical technique used to analyze sample data and the results are applied to the population randomly. This research was carried out in Damai Subdistrict, Kutai Barat Regency, East Kalimantan Province, Indonesia from August to November 2023. The population was 3451 people. Furthermore, the number of samples was determined using the Slovin formula with a sampling error rate of 10% (Sedarmayanti & Hidayat, 2002) resulting in a sample of 96 people. The data collected is in the form of primary data and secondary data. Data collection techniques include questionnaires, observation, structured interviews, and documentation.

The instrument has been put through testing to determine its validity and reliability, and the findings support these claims. With the aid of the SPSS software, the requirements test for classical economics was conducted (Ghozali, 2006); according to the results (Santoso, 2015), it satisfies the requirements for classical economics. Multiple linear regression analysis is the analysis method employed, and the following equation is formulated (Gujarati, 2007):

$$Y = a + b_1X_1 + b_2X_2 + b_3X_3 + b_4X_4 + b_5X_5 + e \dots\dots\dots (1)$$

Information:

Y : Employee performance

a: Constant/value of Y if X=0.

b1, b2 : Regression direction coefficients

X1: CSR economic dimension

X2: CSR education dimension

X3: CSR health dimension

X4: Social and cultural dimensions of CSR

X5: environmental dimension of CSR

e: residual variable

#### 4. RESULT AND DISCUSSION

This research uses multiple linear regression analysis. With the help of the SPSS version 20 computer program, the results obtained are presented in Table 1.

Table 1

Results of multiple regression analysis of the influence of the independent variable on the dependent variable, 2023

Variable	Beta Coef.	t count	Sig. value	Information
CSR economic aspects (X1)	0,286	2,364	0,020	Significant
CSR educational aspects (X2)	0,097	0,662	0,510	Not Significant
CSR health aspects (X3)	0,278	2,128	0,036	Significant
CSR social and cultural aspects (X4)	0,329	2,416	0,018	Significant
CSR environmental aspects (X5)	-0,241	-2,306	0,023	Significant
Constant = 5,165				t table = 1,661
R = 0,736				F table = 2,45
R Square = 0,542				Sig. F = 0,000
F count = 21,323				

Source: Primary data processed by researchers, 2024

Referring to Table 1, a multiple regression equation is prepared based on formula (1), the following results are obtained:

$$Y = 5,165 + 0,286X1 + 0,097X2 + 0,278X3 + 0,329X4 - 0,241X5 \dots (2)$$

Equation (2) shows that:

The constant of 5.165 means that if there is no change in factors (X1), (X2), (X3), (X4), and (X5), then the level of community welfare is 5.165 units.

The regression coefficient for the economic aspect of the CSR variable (X1) has a positive value of 0.286. Contains the meaning that every one unit increase in economic aspects of CSR factors will influence an increase in employee welfare by 0.286 units. and conversely, if there is a decrease in the economic aspect of the CSR factor by one unit, it will affect the decline in community welfare by 0.286 assuming that X2, X3, X4, and X5 remain constant.

The regression coefficient for the educational aspect of the CSR variable (X2) has a positive value of 0.097. Contains the meaning that every one unit increase in the education aspect of the CSR factor will result in an increase in community welfare by 0.097 units. and conversely, if there is a decrease in the educational aspect of the CSR factor by one unit, it will result in a decrease in community welfare of 0.097 assuming that X1, X3, X4, and X5 are constant.

The regression coefficient for the CSR variable for the Health aspect (X3) has a positive value of 0.278. Contains the meaning that every one unit increase in the Health aspect of CSR factors will influence an increase in community welfare by 0.278 units. and conversely, if there is a decrease in the CSR factor for the Health aspect by one unit, it will affect the decline in the welfare of the community around the coal mines in Kutai Kartanegara Regency by 0.278 with the assumptions that X1, X2, X4, and X5 remain constant.

The regression coefficient for the socio-cultural aspect of the CSR variable (X4) has a positive value of 0.329. Contains the meaning that every one unit increase in social and cultural aspects of CSR factors will influence an increase in community welfare by 0.329 units. and conversely, if there is a decrease in the social and cultural aspects of the CSR factor by one unit, it will affect the decline in community welfare by 0.329 assuming that X1, X2, X3, and X5 remain constant.

The regression coefficient for the CSR environmental aspect variable (X5) has a negative value of -0.241. Contains the meaning that every one unit increase in environmental damage will affect the decline in community welfare by 0.241 units. and conversely, if there is a decrease in the environmental damage factor by one unit, it will affect the increase in community welfare by 0.242 assuming that X1, X2, X3, and X4 are constant.

Based on the results of the standardized beta values, it is known that the variables which include economic aspects of CSR, education aspects of CSR, health aspects of CSR, socio-cultural aspects of CSR, and environmental aspects of CSR simultaneously influence the welfare of society. Meanwhile, the dominant variable influencing the CSR variable is the socio-cultural aspect. Furthermore, it is known that the R value (correlation coefficient) is 0.736. This means that the relationship between the dependent variable and the variable is in the strong category (Sugiyono, 2001).

#### **4.1 The influence of economic aspects of CSR on community welfare**

Research findings show that the economic aspect of CSR has a positive and significant effect on the welfare of communities around coal mines in Damai Subdistrict, Kutai Barat Regency. This shows that the CSR program is improving the community's economy (real or meaningful increase in income towards increasing community welfare in coal mining areas in Damai Subdistrict, Kutai Barat Regency. It is understood that if programs increase the economy (income) of the community through programs to increase rural MSMEs, it will certainly be able to improve community welfare. As research results show, respondents' answers to economic aspects of CSR programs such as programs to increase income, increase business opportunities, and other programs that can improve the opinions of families in communities around coal mining gave answers that tended to be positive. The company has implemented CSR programs such as helping to build a Swallow House which is geared towards becoming a Village-Owned Enterprise (BUMKA) and organizational managerial training.

This research is in line with the results of research (Syarifuddin, 2020) examining the impact of CSR on community welfare. The results of the research are that the partnership and environmental development program variables have a significant effect on welfare. The results of this research are in line with the results of research (Djamaluddin et al., 2021). This research is different from the results of research (Razak et al., 2022) examining the implementation of PT Vale Indonesia's social responsibility in increasing the empowerment and welfare of the community around the company. The results of the research are that the implementation of corporate social responsibility (CSR) to empower communities around the company through programs and productive economic business activities as a group has been implemented institutionally, but has not been able to significantly improve community welfare.

#### **4.2 The influence of CSR aspects of education on community welfare**

The study's findings demonstrate that the company's educational component of its corporate social responsibility program, which aims to improve community welfare in coal mining communities, has a favorable but not statistically significant ( $0.510 > 0.05$ ) impact on community welfare. The inclination of respondents' responses to be favorable suggested that the corporation had developed a CSR program on the educational front so that people may increase access to education. The company's implementation of the CSR program did not fully incorporate the instructional component. Respondents' answers tended to be negative. For this reason, the educational aspect of the CSR program which aims to ensure that society receives equitable education can be optimized, such as it can be implemented in the form of providing scholarships to all eligible members of society. The education program has been implemented in the form of providing scholarships, but not all people have received them, because there is a minimum IP requirement. Likewise, the educational aspects of the CSR program, most respondents stated that this program was unfair to society. However, the existence of this educational aspect of the CSR program has been able to

improve educational infrastructure for the community. This research is in line with the results of research (Supriyatna et al., 2016) examining the influence of corporate social responsibility (CSR) on community welfare. The results of the research are that CSR (Corporate Social Responsibility) programs are currently not fully realized, because the company's CSR program is a long-term program.

#### **4.3 The influence of CSR health aspects on community welfare**

The research results show that the influence of CSR health aspects (X3) on community welfare (Y) has a positive and significant effect. This is indicated by the calculated t value being greater than the t table value ( $2.128 > 1.661$ ) and the significance value being smaller than 0.05 ( $0.036 < 0.05$ ). CSR programs in the health aspect carried out by companies have a positive and significant effect on community welfare, which can be seen from the answers of respondents who tend to answer that CSR programs in the health sector carried out by companies can improve health services and provide more equitable services. This research is in line with the results of research (Ningtyas et al., 2022) examining the implementation of corporate social responsibility at PT. Aneka Tambang Tbk. UBPN Southeast Sulawesi. The results of the research are that CSR programs in the health sector carried out by the government provide benefits for the welfare of society.

#### **4.4 The influence of social and cultural aspects of CSR on community welfare**

The research results show that the influence of social and cultural aspects of CSR (X4) on the welfare of communities around coal mines in Damai Subdistrict, Kutai Barat Regency has a positive and significant effect. This is indicated by the calculated t-value being greater than the t - table value ( $2.416 > 1.661$ ) and the significance value being smaller than 0.05 ( $0.018 < 0.05$ ). The social and cultural aspect of the CSR program carried out by the company can be approved by the community. The condition of harmonious social relations can still be maintained with this CSR program. Likewise, this program can also increase the growth and development of mutual respect in society. However, with the CSR program implemented by the company, respondents stated that conflict in society had not reduced. Likewise, CSR programs have not improved the culture of the local community.

The results of this research are in line with the results of research (Ningtyas et al., 2022) examining the implementation of corporate social responsibility at PT. Aneka Tambang Tbk. UBPN Southeast Sulawesi. The results of the research are that social aspects of CSR programs provide benefits to regional independence. This research is also in line with the results of research (Djamaluddin et al., 2021) examining the influence of the implementation of corporate social responsibility at PT. Vale to the welfare of society. The results of the research are that corporate social responsibility targets, social issues, and corporate relations programs have a significant positive influence on improving people's welfare.



#### **4.5 The influence of environmental aspects of CSR on community welfare**

The research results show that the influence of environmental aspects of CSR (X5) on community welfare (Y) has a significant effect ( $\alpha$  value =  $0.023 < 0.05$ ). Based on the results of respondents' answers to the question whether environmental aspect CSR programs have created a healthy environment, have created a safe environment, and have made environmental improvements, they tend to answer negatively. This indicates that the company has not optimally improved the environment. This significant result also shows that if companies carry out increased environmental damage, it will significantly affect the welfare of society. Another thing that the company still lacks attention to is that the company's guarantee that the availability of agricultural land has not been fulfilled and the company's guarantee that it will not change the function of rice fields is also felt by the community to have not been implemented optimally. This research is in line with the results of research (Syarifuddin, 2020) examining the impact of CSR on the welfare of PT livestock communities. PLN Tanjung Jati B. The results of the research are that environmental development has a significant effect on welfare.

#### **4.6 The influence of CSR (economic, educational, health, socio-cultural and environmental aspects) simultaneously on Community Welfare**

The research results show that the independent variables CSR economic aspects (X1), CSR educational aspects (X2), CSR health aspects (X3), CSR socio-cultural aspects (X4), and CSR environmental aspects (X5) have a significant effect on community welfare (Y), because the calculated F is greater than the F table ( $21.323 > 2.45$ ) and the significance value is 0.000. Even though there are partial research results for the educational aspect of the CSR variable (X2), the results are not significant, but together the variables have a significant effect on the dependent variable (community welfare). This research is in line with the research results of (Syarifuddin, 2020), (Djamaluddin et al., 2021), (Astuti, 2018) and (Ningtyas et al., 2022). The results of the research are that CSR programs have a positive and significant effect on community welfare. This research is different from the results of research (Razak et al., 2022) that the implementation of CSR has not been able to improve community welfare.

Basically CSR or in the mining sector is called the Community Empowerment Program (PPM) which basically aims to improve community welfare. Likewise, as far as possible, reduce various conflicts that arise from the company's existence. Once the company's operations are understood, it will have positive and negative impacts on society. Of course, to reduce negative impacts and increase positive impacts, a CSR program is implemented. As research results show how important it is that CSR programs must be implemented. If the CSR program can be implemented well according to targets, it will improve community welfare.

## 5. CONCLUSION

The results of this study came to numerous conclusions, one of which being that there is a significant influence and relationship between the independent and dependent variables, as shown by the values of R square = 0.542 and R = 0.736. Additionally, based on the research objectives, the following conclusions can be drawn: a) CSR economic aspects (X1) have a positive and significant effect ( $0.020 < 0.05$ ) on the welfare of the people of Damai District, West Kutai Regency, b) CSR education aspects (X2) have no significant effect ( $0.510 > 0.05$ ) on people's welfare, c) CSR health aspects (X3) have a positive and significant effect ( $0.036 < 0.05$ ) on community welfare, d) CSR social and cultural aspects (X4) have a positive and significant effect ( $0.018 < 0.05$ ) on community welfare, e) CSR environmental aspects (X5) have a significant effect ( $0.023 < 0.05$ ) on community welfare. CSR economic aspects (X1), and f) CSR educational aspects (X2), CSR health aspects (X3), CSR social and cultural aspects (X4), and CSR environmental aspects (X5) together (simultaneously) have a significant effect ( $0, 00 < 0.05$ ) on the welfare of the people of Damai District, West Kutai Regency (Y).

Referring to the research results, several recommendations that can be submitted are: 1) companies should implement CSR so that it is evenly distributed to the community, 2) optimize CSR programs that are able to improve the community's economy by paying attention to the potential of local communities, 3) companies should pay attention to environmental comfort and protect land. Sustainable agriculture, 4) companies should not carry out land conversion.

## REFERENCES

- Alfian, N., & Rahayu, R. P. (2019). Implementasi Program Csr Dalam Peningkatan Kesejahteraan Masyarakat Melalui Pengembangan UKM di Pamekasan. *AKTIVA Jurnal Akuntansi Dan Investasi*, 3(2), 188–197.
- Astuti, L. (2018). Corporate Social Responsibility (CSR) Terhadap Kesejahteraan Masyarakat di Sekitar PT Panca Usaha Palopo Plywood. *Jurnal Akuntansi STIE Muhammadiyah Palopo*, 4(1), 37–51.
- Dessler, G. (1992). *Manajemen Personalia*. Jakarta: Erlangga.
- Djamaluddin, M., Agustang, A., Idkhan, A. M., & Rifdan. (2021). Pengaruh Implementasi Corporate Social Responsibility PT. Vale Terhadap Kesejahteraan Hidup Masyarakat. *Jurnal Governance and Politics (JGP)*, 1(2).
- Dunn, W. N. (2003). *Pengantar Analisis Kebijakan Publik* (2nd ed., Vol. 5). Yogyakarta: Gadjah Mada University Press.
- Ghozali, I. (2006). *Aplikasi Analisis Multivariate SPSS Dengan Program SPSS*. Semarang: Badan Penerbit Universitas Diponegoro.
- Gujarati, D. N. (2007). *Dasar-Dasar Ekonometrika* (Vol. 1). Jakarta: Penerbit Erlangga.

- Kartasasmita, G. (1996). *Pembangunan Untuk Rakyat: Memadukan Pertumbuhan dan Pemerataan*. PT. Jakarta: Pustaka Cidesindo.
- Ningtyas, C. P., Kambolong, M., & Makmur, M. (2022). Implementasi Corporate Social Responsibility Pada PT. Aneka Tambang Tbk. *UBPN Sulawesi Tenggara. Journal Publicuho*, 5(4), 1091–1112.
- Pakpahan, A. (2021). *Kemerdekaan Bagi Petani Kemerdekaan Untuk Semua*. Jakarta: Yayasan Pustaka Obor Indonesia.
- Putra, D. K. S. (2015). *Komunikasi CSR Politik*. Jakarta: Prenadamedia Group.
- Razak, R., Yunus, R., Hasbi, & Rajab, M. (2022). Implementasi Tanggung Jawab Sosial PT Vale Indonesia dalam Meningkatkan Keberdayaan dan Kesejahteraan Masyarakat Sekitar Perusahaan. *Jurnal Neo Societal*, 7(1), 31–39.
- Sa'adah, S., & Azis, E. (2019). Pengaruh Pemberian CSR Dana Pendidikan dari PT. Internusa Jaya Sejahtera Terhadap Peningkatan Kesejahteraan Masyarakat. *Jurnal Ilmu Manajemen Dan Bisnis*, 10(1), 43–50.
- Samuelson, P. A., & Nordhaus, W. D. (2003). *Ilmu Mikroekonomi*. Jakarta: PT. Media Global Edukasi.
- Santoso, S. (2015). *Menguasai SPSS 22 From Basic TO Expert Skills*. PT Elex Media Komputindo.
- Sastrohadiwiryono, B. S. (2005). *Manajemen Tenaga Kerja Indonesia: Pendekatan Administratif dan Operasional (Vol. 3)*. Jakarta: PT. Bumi Aksara.
- Sedarmayanti, & Hidayat, S. (2002). *Metodologi Penelitian*. Bandung: CV. Mandar Maju.
- Stiglitz, J. E., Sen, A., & Fitoussi, J.-P. (2011). *Mengukur Kesejahteraan Mengapa Produk Domestik Bruto Bukan Tolok Ukur Yang Tepat Untuk Menilai Kemajuan*. Bintaro: Marjin Kiri.
- Sugiyono. (2001). *Metode Penelitian Bisnis*. Bandung: CV. Alfabeta.
- Sugiyono. (2012). *Metode Penelitian Kuantitatif, Kualitatif dan R&D*. Bandung: Penerbit Alfabeta.
- Supriyatna, D., Purwadi, & Rahayu, E. (2016). Pengaruh Corporate Social Responsibility (CSR) Terhadap Kesejahteraan Masyarakat Sekitar Perkebunanpt. Rea Kaltim Plantations. *JURNAL MASEPI*, 1(1).
- Syarifuddin, M. C. (2020). Dampak CSR terhadap Kesejahteraan Masyarakat Binaan Ternak PT. PLN Tanjung Jati B. *Efficient*, 3(1), 625–633.
- Urip, S. (2014). *Strategi CSR: Tanggung Jawab Sosial Perusahaan*. Tangerang: Penerbit Lentera Hati.